



EXCELLENCE - INNOVATION - OPPORTUNITY - SUCCESS

Westport Campus

Stage 5 Program of Studies

Year 9 2024 - Year 10 2025



Contents

Campus Principal's Message	3
Introduction to Stage 5 Curriculum	4
NSW Education Standards Authority - NESA	5
Record of School Achievement - RoSA	5
Assessment- Years 9 and 10	6
Voluntary Contributions and Elective Fees	6
Summary of Courses	7
Mandatory Courses (Core subjects)	8
Electives for Year 9 and 10	12



ONE COLLEGE
MANY OPPORTUNITIES

College Principals Message

Stage 5 courses are an exciting time in our student's academic journeys. It is a time that offers students a more individualised approach to their learning through the selection of elective subjects that cater to student's interests and academic pursuits. Elective subjects are designed to build student autonomy and support them to explore areas of learning that may lead them on the path to their future career.

At Hastings Secondary College, we commit to providing a varied and engaging range of elective options that present rigorous learning opportunities for students. Each board endorsed course is programmed to build student capacity and skill set through structured tasks, activities, and topics. Students are supported to explore a higher-level understanding of their subjects, while accessing resources, fieldtrips and expertise that contribute to their ongoing development and academic growth.

We celebrate and respect the individual learning of each and every student and aim to provide study pathways that encourage individual growth, happiness at school and engaging learning experiences. Students are encouraged to choose elective courses that appeal to their own interests and avoid following the choices of their friends.

Please spend time to read the information presented in this booklet carefully and enjoy the learning journey you prepare to embark on in your Year 9 and 10 studies at Hastings Secondary College.

Karen Noble

Campus Principal

Introduction to Stage 5 Curriculum

This booklet has been prepared to assist students and parents navigate the curriculum structure on offered to students in Stage 5 at Hastings Secondary College. It should be used by students and families as a reference for the patterns of study available to students, as well as a guide for essential information about each subject and course and the way these are assessed and graded.

The Stage 5 curriculum culminates in the award of grades, which are forwarded to the NSW Education Standards Authority (NESA) for the Record of School Achievement (RoSA).

To support students at Hastings Secondary College to continue their studies in Years 11 and 12 for the award of the Higher School Certificate, student work in Stage 5 is nevertheless crucial for future success. Over the next two years, students will develop appropriate study skills and self-discipline while gaining skills and knowledge that will be essential for further learning.



Hastings Secondary College's innovative Stage 5 curriculum structure allows for a broad range of electives, and it is important that students discuss these many options with their parents or care providers and choose subjects and courses that are commensurate with their skills, abilities, and interests.

Students should seek advice from appropriate staff if they are unsure of any details prior to making their final decision.

The commencement of Stage 5 is an exciting time for students. They are offered new challenges and for the first time in their school careers have real choices in terms of the curriculum they study.

In Year 9 students will select and undertake 2 X 2-year electives (200 hours) and 1 elective for 1 year (100 hours), which then allows students to select a different 1 year elective (100 hours) to study in Year 10.



NSW Education Standards Authority

Stage 5 Eligibility

Students entering Year 9 are eligible for the NSW Education Standards Authority (NESA) credential, the Record of School Achievement (RoSA) when they have completed Stage 5 at the end of Year 10.

The RoSA will be issued to students only if they complete Year 10 and leave school before they complete the HSC.

Students must have:

- Attended a government school, or have attended a registered non-government school to which a current certificate of accreditation for presentation of candidates for the Record of School Achievement applies, or have attended a school outside New South Wales recognised by NESA
- Participated and satisfactorily completed courses of study which have been determined as appropriate by the NESA for the Record of School Achievement
- To the NESA's satisfaction, undertaken the requisite examinations or other forms of assessment
- Completed Year 10
- Students completing Year 12 will be advised of their RoSA grade or a record of achievement which acknowledges their HSC.



Record of School Achievement - RoSA

Issuance of RoSA

Students, who the principal has indicated are leaving school and have met all the requirements, will receive a Record of School Achievement credential from the NSW Education Standards Authority (NESA).

Students, who are leaving school, but who have not met the requirements for the Record of School Achievement, will receive a Transcript of Study from NESA.

End of the school year for school leavers

A requirement for the award of the Record of School Achievement is that students attend until the final day of Year 10 as determined by the principal.



Assessment- Years 9 and 10

In NSW student achievement is reported against a set of achievement standards determined by NSW Educations Standards Authority (NESA) These standards are based on what students are expected to learn at each stage and measured against how well they meet those expectations.

The A to E grade reflects the level of achievement demonstrated by the student at the end of the course

Teachers make professional, on-balance judgements about which grade best matches each student's level of achievement.

Students with disability may require adjustments to assessment activities to enable access to the task and equitable opportunity to demonstrate what they know and can achieve.

Hastings Secondary College provides students and families with and assessment handbook at the beginning of the school year. The handbook includes the assessment policy and assessment schedules for all courses. The policy and schedules align with the NSW Educations Standards Authority (NESA) assessment and reporting requirements in each course.

Assessment schedules outline the type of task, indicates the knowledge, skills and outcomes being assessed, the timing and weight of each task, as well as the marking criteria for the task. Assessment tasks contribute to the student's levels of achievement (A-E) in their reports.

Assessment tasks are distributed to students at least 2 weeks prior to the due date on a formal assessment notification. Assessment tasks may include projects, research, tests and in class assessment.

Fees

Voluntary Contributions

The College endeavours to provide the best education for its students.

Voluntary contributions charged by the College contribute towards the provision of essential services and equipment across the campuses and provide access to the best quality resources and materials to enhance the learning experiences of our students.

Any family that may be unable to pay this contribution per term, can alternatively pay in fortnightly or monthly instalments.

Elective Course Fees

Some courses carry specific fees to cover the cost of materials and consumable items purchased on behalf of the students and used directly by them. Electing a course that incurs a cost requires payment of these fees in full, or in increments at the commencement of the course. These fees are listed in this course handbook.

All contributions and fees are payable at the Campus Administration Office where receipts will be issued, or online (instructions are mailed with your account) Eftpos and credit card facilities are available through your Campus Administration Office.



Summary of Courses

Mandatory Courses

English	8
Mathematics	8
Science	9
History and Geography - HSIE	10
Personal Development Health and Physical Education	11

Elective Courses

Aboriginal Studies	12
Agricultural Technology	12
Big History of the Universe - Big Bang Theory	13
Child Studies	13
Commerce	14
Computing Technology	14
Dance	15
Drama	15

Summary of Courses

Food Technology	16
Graphics Technology	16
History elective - Histories Mysteries	17
Industrial Technology - Metal	17
Industrial Technology - Timber	18
Industrial Technology - Multi-media	18
International Studies	19
iSTEM	19
Language	20
Marine and Aquaculture Technology	20
Music	21
Physical Activity and Sports Studies - PASS	21
Psychology	22
Textiles Technology	22
Visual Arts	23

Mandatory Courses

English

Course Description:

The aim of English is to enable students to understand and use language effectively, appreciate, reflect on and enjoy the English language and to make meaning in ways that are imaginative, creative, critical and powerful.

Language Activities and Delivery

Students will respond to and compose texts in the four modes:

- Speaking and Listening
- Reading
- Writing
- Viewing and Representing

They will do this in a range of contexts, including:

- Academic and Literature
- Mass Media and Everyday communication
- Personal expression

The units of work are largely approached through thematic organisation, sequenced to be appropriate to the maturity and experience of the students.

Modules vary according to the needs, interests and capacities of the students who are encouraged to take an active part in, and responsibility for, their own learning.



Mandatory Courses

Mathematics

Course Description:

Mathematics has five strands:

- Number
- Patterns and Algebra
- Data
- Measurement and Space
- Geometry



All students follow a similar study pattern in Years 9 and 10. Some students will have the opportunity to be extended to achieve more and different outcomes to other students.

Students wishing to study the higher levels of Mathematics in the senior years (Mathematics Advanced, Extension 1, Extension 2) should be completing the Stage 5.3 course.

The Stage 5.1 and 5.2 Mathematics courses are designed to prepare students for the Mathematics Standard course in Year 11.

All Mathematics classes in Years 9 and 10 are streamed. Students are placed in the most appropriate level by the Mathematics Faculty after considering the student's progress in Year 8.

Where appropriate, classes are formed to cater for:

- Talented students to extend their work.
- Those students who have difficulties with numeracy.

A **scientific calculator** is required. Calculators must be approved hand-held, battery-operated models which are silent in operation. At Hastings Secondary College calculators are available for purchase at cost price.

Mandatory Courses

Science

Course Description:

Science aims to increase the ability of students to process information critically, enabling them to better understand the world around them and both benefit from and contribute to society because of their understanding of how things work.

Students will be given the opportunity to immerse themselves in the wonder and awe of Science. We emphasise that Science is a creative and collaborative human endeavour that helps students make sense of their world.

Students gain practical and critical thinking skills and are engaged in scientific method, data collection and data analysis. Students take part in a range of hands-on practical experiences to enhance their learning and provide opportunity to expand their knowledge and understanding.



Mandatory Courses



Topics Studied in Years 9 and 10 include:

Year 9	Year 10
Co-ordination / Diseases	Working Scientifically
Waves	Chemical Reactions
The Big Inflation	Electricity
The Periodic Table/Atomic Theory	Motion
Plate Tectonics	Evolution
Environmental Science	Biotechnology
Energy Transfers	Modern Chemistry
	Investigating Science (Working Scientifically 2)

Mandatory Courses

Personal Development Health and Physical Development

Course Description:

PDHPE provides a strengths-based approach towards developing the knowledge, understanding and skills students need to enhance their own and others' health, safety, wellbeing, and participation in physical activity in varied and changing contexts.

The course provides opportunities for students to develop self-management, interpersonal and movement skills to help students become empowered, self-confident, and socially responsible citizens.

Developing movement skills and participating in physical activity are integral to the PDHPE course. Students will be provided with the opportunity to participate in physical activity on a weekly basis as a minimum part of the PDHPE syllabus. For students with a disability, teachers consider relevant and appropriate adjustments to movement experiences.



Mandatory Courses

PDHPE contributes significantly to the cognitive, social, emotional, physical and spiritual development of students. It provides opportunities for students to learn about, and practice ways of, adopting and maintaining a healthy, productive and active life.

The PDHPE Years 7-10 syllabus content is shaped by five propositions organised into three content strands.

Five Propositions:

- Take a strengths-based approach
- Value movement
- Develop health literacy
- Include a critical inquiry approach
- Focus on educative purposes

Three content strands:

- Health, Wellbeing and Relationships
- Movement Skill and Performance
- Healthy, Safe and Active Lifestyles



Elective Courses

Aboriginal Studies

Fees:	Nil	
Westport	2 yr	1 yr

Course Description:

Aboriginal Studies provides students with the opportunity to gain knowledge and understanding of Aboriginal Peoples of Australia, their cultures, and lifestyles. It is of value to both Aboriginal and non-Aboriginal students. All students develop an appreciation of Aboriginal identity and experiences.



Students have the opportunity to develop an appreciation of the unique value of Aboriginal Peoples and their cultures to the Australian identity. They also gain knowledge about contemporary issues affecting Aboriginal communities across Australia. The study of the local community and other Aboriginal communities is important to developing an understanding of the diversity of Aboriginal Peoples and communities.



Elective Courses

Agricultural Technology

Fees:	\$30	
Westport	2 yr	1 yr

Course Description:

Agriculture gives students an opportunity to develop an all-round understanding of the agriculture industry. The course has a 50% practical component where students learn skills such as vegetable production, animal handling and machinery use. Students study four major enterprises in the course, one plant enterprise and three animal enterprises. This course provides students with the opportunities to:

- Develop very practical skills to cope with real life responsibilities
- Develop skills to grow plants or care for small or large animals
- Budget and develop economic skills
- Use computers to manage farm simulations and publish work
- Appreciate agriculture studies as a pathway to many career options.

Students will gain a range of practical skills and knowledge managing animal enterprises such as poultry and cattle. They will be taught skills in animal handling as well as a variety of husbandry practices. They will learn how to manage their own vegetable enterprise throughout the year and harvest their own produce. Students will also gain skills in using the tractor and other machinery during this course.



This course will provide a pathway to senior studies such as Biology, Agriculture, Primary Industries (VET) as well as TAFE courses in Rural Studies, Veterinary Nursing, Landscaping and Horticulture.

Elective Courses

Big History of the Universe - Big Bang Theory

Fees:	\$30
Westport	2 yr only

Course Description:

Big History course gives students an understanding of the history of the universe from the 'big bang' to the modern day and beyond, through an exploration of the themes and patterns that can help us better understand the world we live in. This course is designed for students curious about seeking answers to big questions regarding the history and development of our universe, including the origin of our species. Big history will take students on a deep dive, the universe from a multidisciplinary perspective.

Big history explores the history of the universe and the Earth from a human perspective. Students will learn about the big bang, star and galaxy formation, synthesis of chemicals, building of planets, emergence of life, evolution of humans, the development of civilisation and agriculture, the creation of our connected world, and building perspectives and hypotheses on the future.

Big history will develop students' ability to synthesise information; hypothesise and develop arguments; develop key critical thinking skills. Big history addresses the need for students to use interdisciplinary understanding to solve problems and develop critical thinking skills.

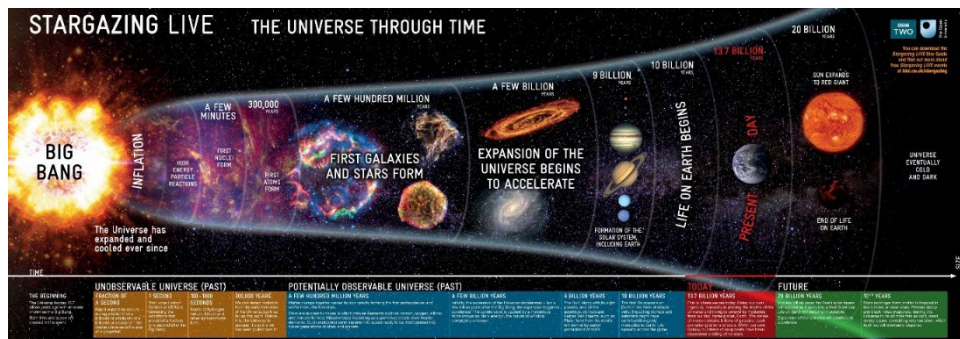

Elective Courses

Child Studies

Fees:	\$15
Westport	2 yr 1 yr

Course Description:

Child Studies is designed for those looking for career pathways in child development e.g. Speech pathology, nursing, and childcare and to offer practical and expert information to encourage responsible and effective parenting for the future.

The aim of the Child Studies course is to develop skills and strategies to give students knowledge about the growth and development of young children. This will be an asset to students both on a personal level and as a career option. Students will develop strategies that will enable them to provide safe and nurturing care for young babies and children.



Students will learn to identify, create and evaluate solutions to enhance child wellbeing. Students will become aware of and learn to access a range of relevant community resources and services.

They will learn to identify and evaluate what enhances a child's wellbeing. It contributes to the development of an understanding and appreciation of the range of ways students can positively impact on the wellbeing of children through roles in both paid and unpaid contexts.

Child Studies includes study of family preparation, newborn care and the influence and impact of nutrition, play, technology and the media.



Elective Courses

Commerce

Fees:	\$20	
Westport	2 yr	1 yr

Course Description:

If you have an interest in money, business, law, employment issues or travel, then this is the course for you.

Commerce enables students to develop the knowledge, understanding, skills and values that support making sound decisions about consumer, financial, legal, business and employment issues. It develops the ability to research information, apply problem solving strategies and evaluate options in order to make informed and responsible decisions as individuals and as part of the community.

Core

Consumer Choice and Personal Finance, learning about making responsible spending, saving, borrowing and investment decisions as part of personal financial management.

Law and Society and Employment Issues, in which they will develop an understanding of their legal rights and responsibilities and how laws affect individuals and regulate society. They also learn about commercial and legal aspects relating to employment issues, and their rights and responsibilities at work.

Practical Learning experiences in the core and optional topics:

- The ASX Share market game
- Learning your rights as a consumer, and how to avoid falling into debt with credit cards.
- \$20 Boss challenge: set up your own business.
- Buying a car and renting a house or unit.
- Planning an overseas trip.
- Learning about the law and visiting the courthouse



Elective Courses

Computing Technology

Fees:	\$20	
Westport	2 yr	1 yr

Course Description:

Computing Technology focuses on understanding how computers work, designing solutions, and analysing data. Students learn programming and coding skills, which are useful in a world that relies more and more on technology. They also learn to use hardware and software to manage and protect data while considering important issues like privacy and cybersecurity. Students explore the impact of new technologies on society and the environment and gain hands-on experience with different tools and applications like multimedia, virtual reality, gaming, and networks. The course helps them become confident, creative, and efficient in using technology and prepares them for further education and career opportunities in this field.

Students will spend a major part of their time completing hands on practical activities and projects. They will become safe and responsible users of computing technologies and developers of innovative digital solutions. Students will study a number of options from:

- Modelling networks and social connections
- Designing for user experience
- Building mechatronic and automated systems
- Creating games and simulations
- Developing apps and web software

The course allows students to develop skills through practical application and design to produce and evaluate creative solutions using a range of computing technologies. It is appropriate for all students and requires no prior learning.



Elective Courses

Dance

Fees:	\$50
Westport	n/a 1 yr

Course Description:

Dance provides students with opportunities to experience and enjoy movement as an artform as they perform, compose and appreciate dance. In an integrated study of the practices of performance, composition and appreciation, students develop both physical skill and aesthetic, artistic and cultural understandings. The course enables students to express ideas creatively and to communicate physically, verbally and in written form as they make, perform and analyse dance in various forms.

All students study dance performance, composition and appreciation. Students learn about the elements of dance (space, time and dynamics) and how they link the three practices. They will learn about performing dances with an awareness of safe dance practice, dance technique and performance quality. Students learn about how dance expresses ideas, feelings and experiences as they construct dance compositions to communicate ideas. They also engage in a study of people, culture and society through the study and analysis of dance performances, compositions and dance works of art.

Students learn to use the language of dance and to describe movements using the elements of dance. They view, discuss, read and write about dance. Drawing from experiences gained in performing, composing and appreciating dances, students learn to make connections between the performance of movement and the making of meaning.



Elective Courses

Drama

Fees:	\$50
Westport	2 yr n/a

Course Description:

Drama will provide students with experiences in which the intellect, the emotions, the imagination and the body are all involved and developed through expression, performance, observation and reflection.

Students gain an understanding of the artistic and creative processes needed to make drama, as well as an appreciation of the nature of performance and the connection between performers and their audience.

Students will develop knowledge, understanding and skills, individually and collaboratively through:

- **Making** drama exploring a range of imagined and creative situation in a variety of theatrical environments
- **Performing** devised and scripted drama in a variety of performance techniques, forms and conventions
- **Appreciating** the meaning and function of drama in a social, cultural and personal aspect of the human experience.

Students are encouraged to work collaboratively and develop their skills in Play building, Melodrama, Script writing, Absurdism, Creative thinking, Improvisation, Live Theatre, Stage Crafts and Theatre Sports.



Elective Courses

Food Technology

Fees:	\$80
Westport	2 yr n/a

Course Description:

Food Technology enables students to study many aspects of food presentation and food preparation, whether this is at home or in the commercial environment such as restaurants or shops. It involves students investigating foods through practical hands-on applications.

Food Technology provides students with knowledge and understanding of food properties, processing, preparation, nutrition, and consumption. It addresses the importance of hygiene and safe working practices in the production of food.

Students develop food-specific skills for a range of contexts enabling students to produce quality food products.

The major emphasis of Food Technology is through a range of practical experiences enabling students to explore food-related issues, supporting informed and appropriate food choices.

Themes may include:

- Food preparation, processing, and nutrition.
- Food for Special Occasions - catering and hosting, menu planning, presentation, cake decoration, and food festivals
- Food Service and Catering - for home, restaurants, and cafes.
- Food for Special Needs - menu planning for specific diets and nutritional needs through life.



Elective Courses

Graphics Technology

Fees:	\$10* plus equipment
Westport	2 yr 1 yr

Course Description:

Graphics Technology is important to all students especially in today's technological reliant society.

2D and 3D graphics and digital design are used for printed media, web and communication applications as well as by television broadcasters for live graphics e.g. in news and sports shows.

Our College has the facilities to provide students the opportunity to experience Computer Graphic prototyping and modelling techniques in creating and producing projects in 3D-printing, Laser cutting and Computer Numerically Controlled Machining (CNC).

Students intending to study Industrial Technology, Engineering Studies or Design and Technology in Years 11 and 12 should consider this subject, as it provides a component developed in these courses.

Graphics Technology develops skills in all methods of pictorial or three-dimensional drawing, two-dimensional drawing, sketching, uses of light and shadow, sketching and using colour. All students will gain competencies in the use of Computer Aided Drawing (C.A.D.) by use of computer programs.

Students will also undertake product drawing projects where they will research, design and produce marketing briefs for everyday products. In this way the graphic techniques used in advertising and product promotion are developed.

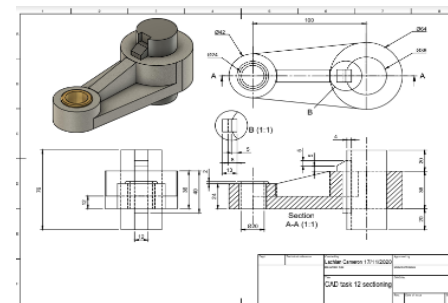

Elective Courses

Histories Mysteries - History elective

Fees:	Nil		
Westport	2 yr	1 yr	

Course Description:

Histories mysteries develops an interest in and enjoyment of exploring the past outside of the compulsory course and following student interests.

Students explore the nature of history and the methods that historians use to construct. Students develop an understanding of how historians investigate and construct such as oral history, museum or archive studies, historical fiction, media, biography, or film.

Historical issues studied include the collection, display and reconstruction of the past, ethical issues of ownership and preservation and conservation of the past. A selection of ancient, medieval, and early modern societies are studied in relation to themes such as war and peace, crime and punishment, music through history.



Elective Courses

Industrial Technology - Metal

Fees:	\$50		
Westport	2 yr	1 yr	

Course Description:

Industrial Technology Metal provides the opportunity for students to develop skills in the use of hand tools, machines, and welders through the construction of projects. Projects are designed to extend skill development.

The workshop is well equipped with lathes, folding equipment, welders, and industry quality fabrication equipment. Theory work will cover topics such as the design of metal products, the properties and uses of metal, metal production technology and WHS.

Students learn metal fabrication and machining techniques and skills using technical drawing and communication ideas and design. Projects develop their craftsmanship and knowledge. Developing a project folio helps demonstrate the practical application of literacy and numeracy communication.



Elective Courses

Industrial Technology - Timber

Fees:	\$40*
Westport	2 yr 1 yr

Course Description:

Industrial Technology - Timber is designed to develop confidence in the skilful use of materials, machines, hand and power tools, equipment, and processes.

Industrial Technology - Timber provides the opportunity for students to design and construct projects using wood. The wood turning lathes may be used by students to produce turned bowls, mallets, and small tables. They learn woodworking techniques and skills using technical drawing and computer programs to assist with planning, presenting and to communicating ideas and design.

Theory work will cover topics such as the design the properties and uses of timber, timber production technology and WHS issues associated with the timber industry.

Safe working practices are emphasised during the course.

Students will achieve a sense of purpose and personal satisfaction in the useful and interesting projects they manufacture.



* Yr 10 major work fee \$35 or BYO timber

Elective Courses

Industrial Technology - Multi-media

Fees:	\$40*
Westport	2 yr 1 yr

Course Description:

This course is designed to provide opportunities for students to explore the multimedia industry in the following areas:

- Video and sound editing to create films or movies. From storyboarding, shooting, and editing to production of an interactive DVD
- 3D Modelling: Creating Virtual Reality animations.
- Computer Animation: Creation of cartoon characters and making them walk / talk.
- Web page design: Planning and creation of a Web page or site.
- Digital Still Photography- Enhancement and Manipulation.
- Brochures and presentations.



This predominantly practical subject allows students to experience these areas using the relevant equipment and programs. It's practical design encourages students' individual creativity. It allows students to investigate traditional, current, and emerging technologies which relate to the multimedia industry and the impact of new and emerging technologies on careers.



Elective Courses

International Studies

Fees:	Nil	
Westport	2 yr	1 yr

Course Description:

International Studies is an exciting course that gives students the opportunity to study a broad range of issues in an international context. The course includes a core study on understanding culture and diversity in today's world, as well as options including but not limited to:

- Culture and social media
- Culture and Sport
- Culture in Film and TV
- Culture and Food
- Culture and Travel
- Culture, science, technology, and change.



International Studies will appeal to students with an interest in Asian cultures and is a good complement to studies in Asian languages. It develops an understanding and appreciation of the culturally diverse society in which we live.

The course will include culture-related excursions to restaurants, museums, cultural centres, and cultural events. It may also provide opportunities for students to communicate with students at schools outside of Port Macquarie, utilising the connected classroom. It will be highly relevant and interesting to students who are considering studies in Geography, Society and Culture, Ancient History, Modern History, Extension History, Legal Studies, Business Studies, Economics, CAFS or any Language in the senior school.

Elective Courses

iSTEM

Fees:	\$40	
Westport	2 yr	1 yr

Course Description:

The importance of STEM subjects is indisputable. Future employment opportunities for our students will be enhanced with STEM based knowledge. Science, Technology, Engineering and. The iSTEM course aims to inspire and challenge students; showing the role and potential STEM in the world in which they live.

It involves 21st century learning and emphasises inquiry-based learning where students are encouraged to learn by becoming familiar with and implementing appropriate real life practical skills and applications. Students will learn to develop their skills using a range of tools, techniques, and processes, including relevant technologies to develop solutions to a wide variety of problems and challenges relating to their present and future needs and aspirations.

The iSTEM course may include:

- STEM and Engineering Fundamentals
- Aerodynamics (making planes and rockets)
- Science and Engineering Challenge
- Design for Space
- Project Based Learning Task
- Robotics
- Computer game creation
- FI in Schools (CO2 cars), Challenge days



Elective Courses

Language - Japanese

Fees:	\$20
Westport	2 yr 1 yr

Course Description:

Language courses provide students with the opportunity to gain effective skills in communicating in the chosen language, to explore the relationship between it and English, and to develop an understanding of the chosen culture.

The study of Language may allow students to:

- Improve literacy skills.
- Become a better thinker and listener.
- Participate in games and activities as part of the learning experience.
- Have some proof of the skills that you have mastered.
- Visit another country.

Government and businesses throughout many countries support programs of student exchange and cultural interchange, which makes it likely that young Australians familiar with another language will find their knowledge particularly rewarding.

Students will develop knowledge, understanding and skills necessary for effective communication in their chosen language and build cultural understanding by reflecting on similarities and differences between their own and the other culture.



Elective Courses

Marine and Aquaculture Technology

Fees:	\$30
Westport	2 yr 1 yr

Course Description:

Marine and Aquaculture Technology develop a students' capacity to design, produce, evaluate, sustain, use and manage marine and water related environments as a key to the future of planet Earth. The course is designed to develop:

- knowledge, understanding and appreciation of marine and aquatic environments.
- the ability to design, set up and maintain aquariums and aquaculture systems.
- the ability to be able to safely snorkel for leisure and observation of marine organisms.
- a knowledge of some of the effects human activity has had on the native fish stocks and our aquatic environments.
- an understanding of marine and freshwater ecosystems and all their life forms.
- an awareness of the importance, scope and diversity of marine and freshwater life in both an Australian and global context.
- a sense of responsibility for the need for wise management practices in the use of fresh water and marine resources.



Elective Courses

Music

Fees:	\$50
Westport	2 yr n/a

Course Description:

Music infuses society and occupies a significant place in world cultures and history of all civilisations and plays important roles in the social, cultural, and spiritual lives of people. At an individual level, music is a medium of personal expression.

Music also allows students to develop their capacity to manage their own learning, work collaboratively and engage the real-world practice of performers, composers and audiences.

Music offers students an opportunity to:

- Learn an instrument for classroom use, for example: keyboard, guitar or drums.
- Participate in music from a wide variety of styles including Jazz, Rock, Australian and Classical music.



- Become more musically literate – i.e. read and compose music in traditional and other forms of notation.
- Develop skills associated with Creative and Performing Arts Industry pathways, for example assembling PAs, lighting and sound.

The main components of Music are:

- Performance: in many styles.
- Creating: Musicology and writing and arranging music for performance.
- Listening: developing aural literacy skills and metalanguage in Music.

Elective Courses

Physical Activity and Sports Studies - PASS

Fees:	Nil
Westport	2 yr 1 yr

Course Description:

Physical Activity and Sports Studies syllabus is to enhance a student's capacity to participate effectively in physical activity, leading to improved quality of life for themselves and others.

PASS aims to enhance students' capacity to participate effectively in physical activity and sport, leading to improved quality of life for themselves and others. Students engage in a wide range of physical activities to develop key understandings about how and why we move and how to enhance quality and enjoyment of movement. PASS also aims to develop leadership and problem-solving skills as well as Sporting and Gameplay IQ.



Throughout the course students will develop skills that develop their ability to:

- work collaboratively with others to enhance participation, enjoyment and performance in physical activity and sport.
- display management and planning skills to achieve personal and group goals in physical activity and sport.
- perform movement skills with increasing proficiency.
- analyse and appraise information, opinions and observations to inform physical activity and sport decisions.

Elective Courses

Psychology

Course Description:

Psychology provides students with an understanding and a critical awareness of the nature of human behaviour and the influence of biological, cognitive and socio-cultural factors on individuals and society.

Students develop knowledge and understanding of human nature by asking questions and undertaking studies.

Through these studies the students will appreciate:

- how people perceive the world around them and how they respond to it,
- how human learning develops, and
- how they relate to others and function within society.

Psychology provides a sound base of knowledge for further study in the faculty areas of PDHPE and HSIE in senior years.

Any student who is considering a career in health, education, childcare, social services, psychology, occupational therapy would find this course beneficial.



Fees:	Nil	
Westport	2 yr	1 yr



Elective Courses

Textiles Technology

Course Description:

Textiles Technology is a very creative and exciting practical subject which provides students with a broad knowledge of the properties, performance, and uses of textiles in which fabrics, colouration, yarns and fibres are explored.

Textiles provide a means of self-expression, cultural significance, and functionality. Students investigate designers and make judgements about the design ideas, materials tools, and quality.

Students will learn to use the creative process to design textile items. Design ideas and experiences are documented and communicated and will show the stages of designing, producing, and evaluating.

Topics that may be covered:

- Fabrics: how they are made, used, and cared for.
- Fashion and design; influences, designers and how to illustrate design briefs.
- Culture; various countries and culture's ideas of fashion and beauty. creation of different articles.

The projects will give students the opportunity to be creative, independent learners while exploring many aspects of textiles and encouraging individuals to express ideas and opinions.



Fees:	\$30	
Westport	2 yr	1 yr

Elective Courses

Visual Arts

Fees:	\$60	
Westport	2yr	1yr

Course Description:

Visual Arts fosters interest and enjoyment in the making and study of art. Visual Arts builds understanding of the role of art, in all forms of media, in contemporary and historical cultures. Visual Arts empowers students to engage in visual forms of communication through collaborative and independent learning. The content provides opportunities for students to investigate the field of visual arts in complex and rich ways. Within the course students develop skills across multiple forms and learn the value of the art making process using their Visual Arts Diary. Students learn:

- about art making practice and historical and critical studies that are informed by the content areas of the Frames and the Conceptual Framework.
- about the world as a source of ideas and create works to communicate to the audience through a variety of forms, and genres.
- how artists develop their intentions in order to develop and informed personal practice for their own art making.

Students develop artworks in two dimensional and three dimensional forms using the content areas as a basis. Students investigate mediums through experimentation using their Visual Arts Diary. Students make artworks using an extended range of materials and techniques. Critical and historical interpretations build essay writing skills and research skills allowing students to value the place of the Visual Arts within society.





EXCELLENCE - INNOVATION - OPPORTUNITY - SUCCESS

<https://hastingssecondarycollege-h.schools.nsw.gov.au/>